

# Suburban Water Heaters

SW3P  
SW6P, PE, PER  
SW6D, DE, DEM  
SW10P, PE, PER  
SW10D, DE, DEM

## Service Manual

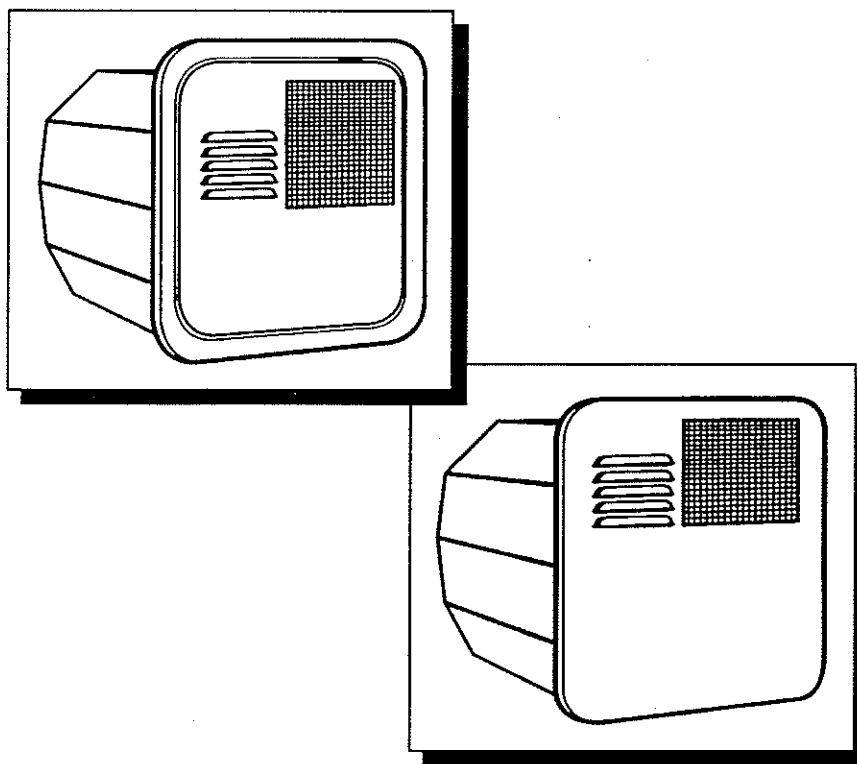

**Suburban**  
Manufacturing Company

a subsidiary of AIRXCEL, Inc.

SUBURBAN MANUFACTURING COMPANY  
Post Office Box 399  
Dayton, Tennessee 37321  
423-775-2131  
Fax: 423-775-7015  
[www.rvcomfort.com](http://www.rvcomfort.com)

## TABLE OF CONTENTS

Suburban Water Heaters .....	4
Model Number Listing Spec Sheet .....	5
Installation Instructions	
Installation of Water Heater .....	6
Installation Using Flush Mount Frame and Door .....	7
Installation Using Radius Frame and Door .....	8
Making Water Connections .....	9
Making Gas Connections .....	9
Making Electrical Connections .....	10
Electrical Connections (re-ignitor models) .....	10
Operating and Lighting Instructions	
Pilot Model .....	11
Pilot with Re-ignitor .....	12
Direct Spark model .....	13
Sequence of Operation for the Direct Spark Ignition .....	14
Electric System	
120VAC Electric Element .....	15
Winterizing/Flushing Instructions .....	15
Odor from Water Heater System .....	15
Anode Rod Function .....	16
Temperature and Pressure Relief Valve .....	17
On/Off Switch .....	18
Thermostat and ECO Switch .....	18
Circuit Board and Electrode .....	18
DSI Gas Valve and Burner .....	19

Pilot Model Gas Valve and Burner ..... 19  
Application Note (Flame Current Measurement) ..... 20  
Flow Chart Pilot ..... 21  
Flow Chart Direct Spark Ignition ..... 22  
Flow Chart Electric Element ..... 23

**Service Tools Required**

- Manometer or U-Tube
- Millivolt Tester
- Voltmeter
- Circuit Board Tester - 641511
- Gas Thermostat Wrench
- Nut Drivers
- Various open End Wrenches
- Phillips Screwdriver
- Flat Head Screwdriver
- LP Leak Test Solution
- Pliers
- Safety Glasses

**NOTE: Our Service Technicians are available to assist you in making repairs or parts replacements from 8:00 a.m. to 5:00 p.m. EST, Monday through Friday (except holidays), by calling 423-775-2131 extension 2. E-mail address for tech support is [info@suburbanmanufacturing.com](mailto:info@suburbanmanufacturing.com).**

## SUBURBAN WATER HEATERS

The Suburban line of water heaters includes high recovery gas, gas-electric and motor aid models with sizes and features to match the requirements of almost any recreational vehicle. Suburban uses a porcelain-lined, steel water heater tank with an anode rod to "absorb" the electrolytical action. The anode rod is attached to the drain plug and can be easily inspected and replaced, as necessary, when the tank is drained.

The module board can be completely protected from moisture and the outside environment by being placed at the rear of the unit inside the coach, which makes it possible to locate the module board on the appliance or on the wall next to the appliance.

The Suburban water heater has a fast recovery time and fewer cool water cycles. Both 6 and 10 gallon water heaters have 12,000 BTU/h input and a recovery rate of 10.2 gallons per hour. Combination gas/electric models are equipped with a 1440 watt element to recover at 6.0 gallons per hour. The 3 gallon water heater has 9,000 BTU/h input and a recovery rate of 7.6 gallons per hour. The tank is insulated with a molded copolymer insulation. This insulation helps retain heat.

All the water heaters are designed for easy installation, operation and maintenance. The controls are located in the front of the water heater along with the anode rod for better serviceability.

### WATER HEATER OVERALL CONSTRUCTION Glass-lined Tank

The steel, glass-lined tanks provide long life under varying water conditions. This same construction is what is used for more than 7 million residential water heaters sold annually. Three (3) year limited tank warranty, replaceable anode rod, high output, fast recovery, and foam jacket are on all gas/electric models.

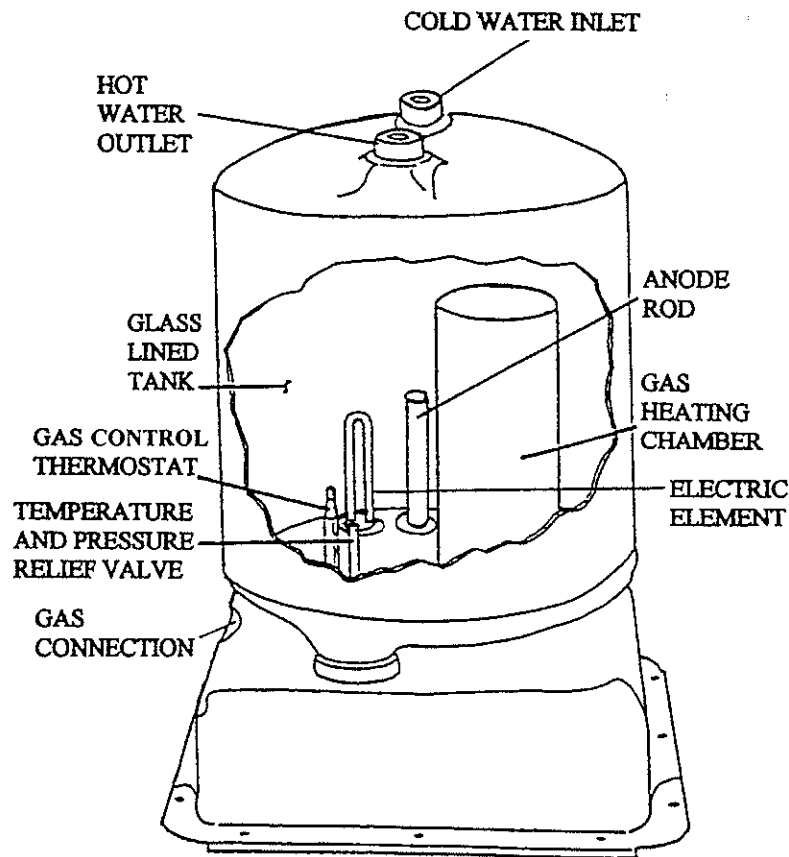

# Suburban

## RV WATER HEATERS

### Spec Sheet

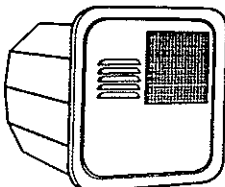
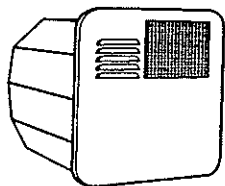

Model Number	Nom. Gals.	BTU/h Input	Height	Width	Depth	Shipping Weight
<b>Standard Pilot</b>						
SW3P	3	9,000	12 11/16"	12 11/16"	16 1/8"	30
<b>Super Performance Pilot</b>						
SW6P	6	12,000	12 11/16"	12 11/16"	19 3/16"	37
SW10P	10	12,000	16 7/32"	16 7/32"	20 1/2"	48
<b>Super Performance Pilot with Reignitor</b>						
SW6PR	6	12,000	12 11/16"	12 11/16"	19 3/16"	37
SW10PR	10	12,000	16 7/32"	16 7/32"	20 1/2"	48
<b>Super Performance Combination Electric and Pilot</b>						
SW6PE	6	12,000	12 11/16"	12 11/16"	19 3/16"	37
SW10PE	10	12,000	16 7/32"	16 7/32"	20 1/2"	48
<b>Super Performance Combination Electric and Pilot with Reignitor</b>						
SW6PER	6	12,000	12 11/16"	12 11/16"	19 3/16"	37
SW10PER	10	12,000	16 7/32"	16 7/32"	20 1/2"	49
<b>Direct Spark Ignition</b>						
SW6D	6	12,000	12 11/16"	12 11/16"	19 3/16"	35
SW10D	10	12,000	16 7/32"	16 7/32"	20 1/2"	49
<b>Electric and Direct Spark Ignition</b>						
SW6DE	6	12,000	12 11/16"	12 11/16"	19 3/16"	37
SW10DE	10	12,000	16 7/32"	16 7/32"	20 1/2"	50
<b>Electric and Direct Spark Ignition with Motor Aid</b>						
SW6DEM	6	12,000	12 11/16"	12 11/16"	19 3/16"	39
SW10DEM	10	12,000	16 7/32"	16 7/32"	20 1/2"	60
<b>Accessories</b>						
520821	Reignitor Kit (Applicable only to models above. See #991801501)					
6261ACW	Door, Colonial White, SW Model, Radius Corner, 3, 6 Gallon					
697205	Door, Colonial White, V Model, Radius Corner, 3, 6 and 8 Gallon					
690578	Door, Colonial White, V Model, Square Corner, 3, 6 and 8 Gallon					
520781	Kit to adapt old style 6 Gallon Door to SW6 Water Heater					
6255ACW	Door, Colonial White, SW Model, Flush Mount, 3, 6 Gallon					
697221	Door, Colonial White, V Model, Flush Mount, 6 Gallon					
520771	Kit to adapt old style Flush Mount Door to SW6 Water Heater					
6257ACW	Door, Colonial White, V Model, Radius Corner, 10 Gallon					
697213	Door, Colonial White, V Model, Square Corner, 10 Gallon					
6259ACW	Door, Colonial White, SW Model, Flush Mount, 10 Gallon					
520787	Door Kit (6 Gallon Aluminum Tank Replacement Kit) Colonial White					
520818	Door Kit (6 Gallon Aluminum Tank Replacement Kit) Polar White					

**WATER HEATERS AND DOORS ARE SOLD SEPARATELY**

Specifications and prices are subject to change without notice.

## INSTALLATION INSTRUCTIONS

Minimum clearance is 0" from combustible construction on sides, top, floor and rear as listed in the installation manual for your specific model. Provide room for access to rear of heater for servicing.

Provide an opening flush with floor in outer wall of coach. Wall of coach should be framed as shown in Figure 1. Maintain inside dimensions listed below. Do not install on carpet unless the carpet is covered by a metal or wood shield covering the entire area underneath the water heater. If preferred, cut away the carpet from this area. Chocks must be in place to secure rear of unit (See Figure 1A).

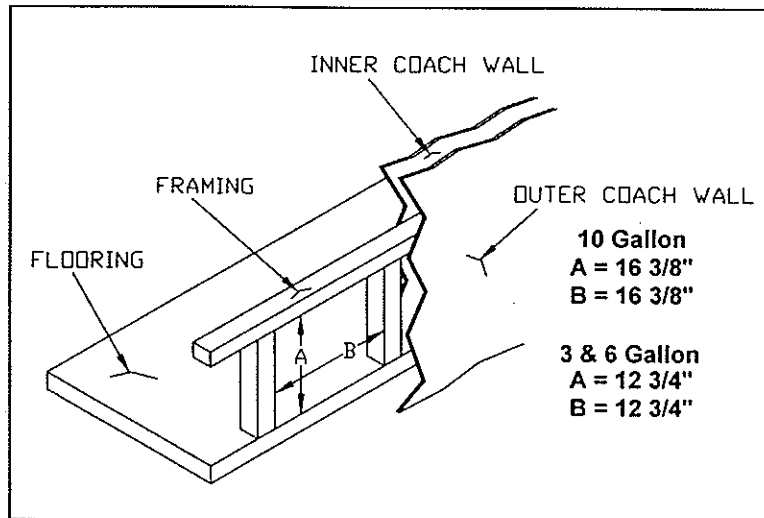

Figure 1

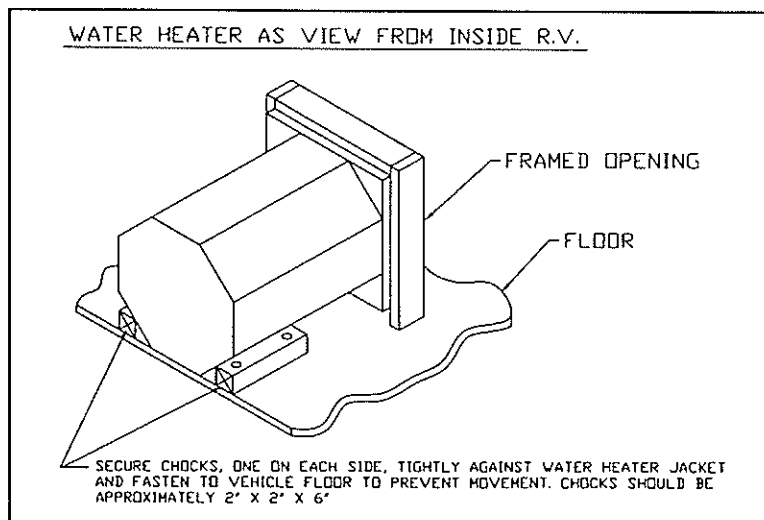

Figure 1A

## INSTALLATION USING FLUSH MOUNT FRAME AND DOOR (3, 6 and 10 Gallon)

**A.** Position heater into framed opening. Slide unit into opening until the front of the control housing is flush with the exterior coach skin as illustrated.

**B.** Secure the control housing to the coach wall (framed opening) at the top and sides of control housing compartment using screws or other suitable fasteners. Recess the screws or fasteners back far enough from the front edge of the control housing (approximately 1 1/2") in order to clear the flange on the door frame. The door frame, when installed, must not overlap onto screw or other fastener head. If due to the wall thickness, it is not possible to secure the water heater without covering the fastener head with the door frame, it is important to not over tighten the fastener and distort the control housing. Over tightening of the fastener may cause leaks between the control housing and the door frame.

NOTE: Caulk around screw or fastener heads to assure water tight seal.

**C.** Install chocks, one on each side of water heater, as illustrated in Figure 1A.

**D.** On mesa or yoder type sidewalls, flatten the wall area around the opening.

**E.** Caulk around framed opening as illustrated in Figure 2.

**F.** Caulk around door frame using 2 beads of silicone caulking (or suitable caulking) one on the flange to seal the control housing and one around back side of frame to seal to coach skin. (See detail A in Figure 2)

**G.** Insert door frame into control housing and secure with four (4) No. 8-15 x 3 1/2" screws provided for 10 gallon applications and (3) No. 8-15 x 3 1/2" screws provided for 6 gallon applications.

**H.** To install door, place the two holes in the bottom of the door over the door pins on the frame. Close the door so that the latch protrudes through the slot in the door. Turn latch 90 degrees to fasten door closed.

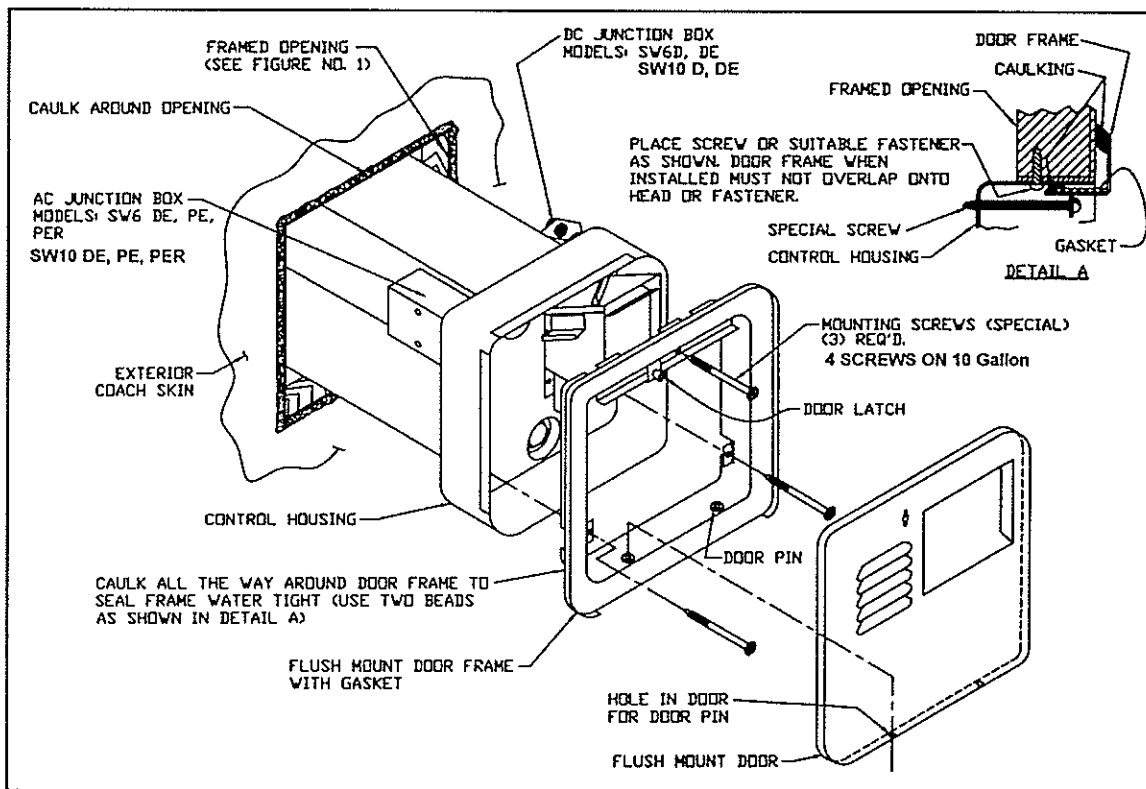

Figure 2

## INSTALLATION USING RADIUS FRAME AND DOOR (3 and 6 Gallon Only)

- A. Position heater into framed opening as illustrated.
- B. On mesa or yoder type sidewalls, flatten the wall area around the opening.
- C. Caulk around framed opening (trailer skin) as illustrated in Figure 3.
- D. Apply a bead of silicone caulking (or suitable caulking) around the inner edge of the control housing. See detail "A" in Figure 3. This will seal the frame to control housing.
- E. Apply a bead of silicone caulking (or suitable caulking) around back side of door frame. See detail "A" in Figure 3. This will seal frame to coach skin.
- F. Fit the door frame into control housing (over the caulking already applied) and pull frame tight to control housing using the three (3) No. 8-15 x 3 1/2" screws provided.
- G. Push water heater into framed opening until back side of door frame is against the side of the coach and firmly attach with screws around the perimeter of the frame. NOTE: The two holes in bottom of frame identified as "A" in Figure 3 are also used to mount door hinge to the frame.
- H. Install chocks, one on each side of water heater, as illustrated in Figure 1A.
- I. Attach door to frame as illustrated in Figure 3.
- J. Close the door so that the door latch protrudes through the slot in the door. Turn latch 90 degrees to fasten door shut.

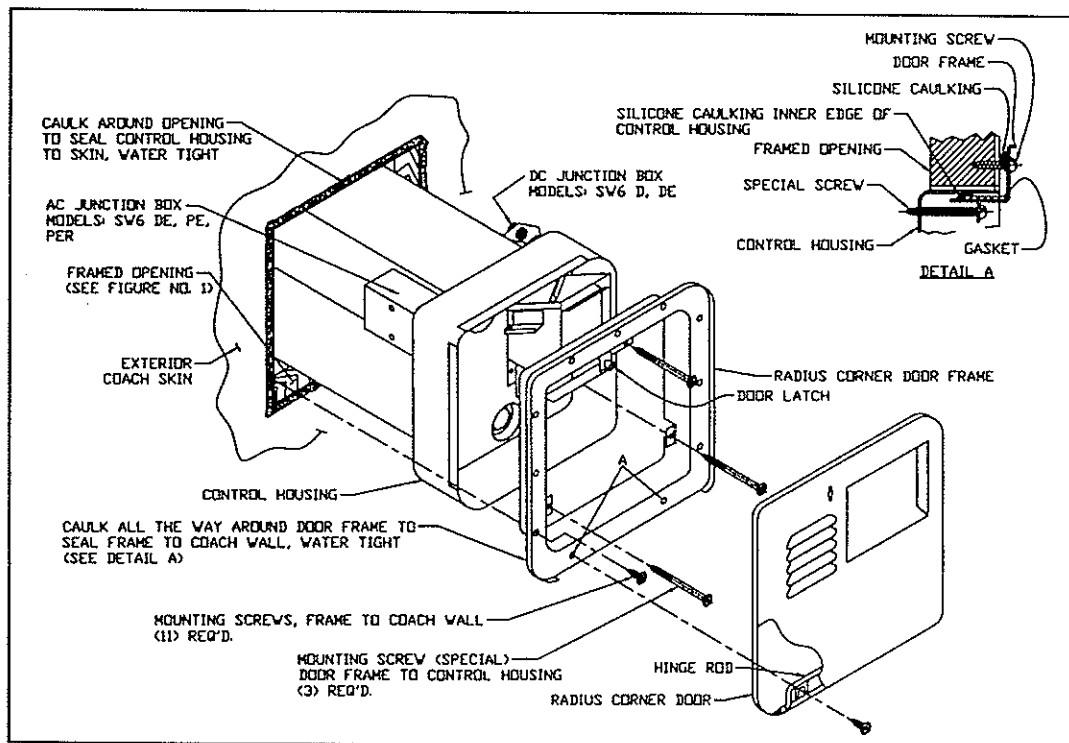

Figure 3



## MAKING WATER CONNECTIONS

A. Water connections are made at the rear of the water heater. Refer to Figure 4. Connect the hot and cold water lines to the 1/2" female pipe fitting provided on the rear of the tank. These fittings are marked "HOT" and "COLD". Use a pipe thread compound suitable for potable water or pipe thread tape on all connections to assure they will not leak.

NOTE: Inside each fitting is a plastic fill tube. Its purpose is to enhance water circulation. DO NOT REMOVE THE PLASTIC FILL TUBES.

B. Fill tank with water. Open both hot and cold water faucets to expel air from the tank. When tank is filled and water flows from faucets, close both faucets and check all connections for leaks.

CAUTION: If air pressure is used to check for leaks, the pressure must not exceed 30 PSI.

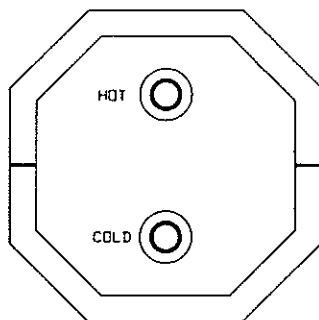

Figure 4

## GAS PRESSURE REQUIREMENTS

Supply Pressure: Minimum 11" WC, Maximum 13" WC  
WC - water column

## MAKING GAS CONNECTIONS/GAS PRESSURE REQUIREMENTS

A. Connect the gas supply line to the 3/8" flare fitting at gas valve located in the control housing. When making the gas connection, hold the gas fitting on the valve with a wrench when tightening the flare nut. Failure to hold fitting secure could result in a gas leak due to fitting being damaged.

NOTE: It will be necessary to remove the grommet from the control housing to make the gas connection at the valve. Reinstall the grommet once the gas connection is completed. Caulk and seal grommet as illustrated.

B. Turn on gas and check all fittings and connections for leaks using an LP Leak Test Solution (See page 3). Correct even the slightest leak immediately.

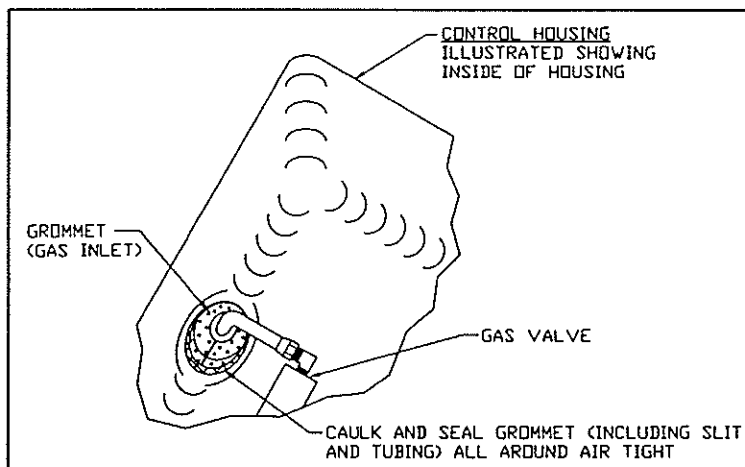

Figure 5

## 120 Volts A.C. 12 Volts D.C. VOLTAGE REQUIREMENTS DC/AC VOLTAGE REQUIREMENTS

Models with pilot re-ignitor and all DSI Models	All models with electric elements
Minimum 10.5 Volts D.C.	Total connected Watts 1440 - 12 amps
Maximum 13.5 Volts D.C.	

### MAKING ELECTRICAL CONNECTIONS

- A. Refer to Figure 2 for location of A.C. and D.C. junction box on specific models. All A.C. connections must be inside junction box.
- B. The electrical connections must be made in accordance with local codes and regulations. In the absence of local codes and regulations, refer back to the installation and operation manual.
- C. Be sure the switch for the electrical element is "OFF" and that the water heater is filled with water before powering element. Failure to do so will result in burn-out of the electrical element.

NOTE: Check rating plate and wiring diagram (Figure 6) before proceeding. Install a fused safety switch or circuit breaker of adequate capacity between heater and electrical power source. Attach the black and white wires from the fused switch or breaker to corresponding colored wires in heater junction box. A wire from a well grounded source must be attached to the green nut in the junction box.

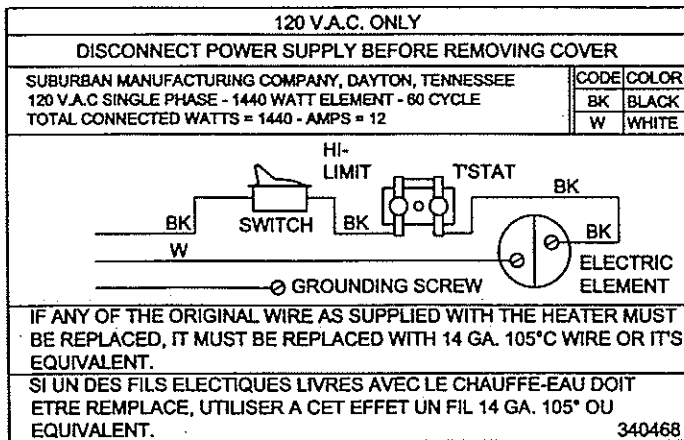

Wiring Diagram 120 V.A.C.

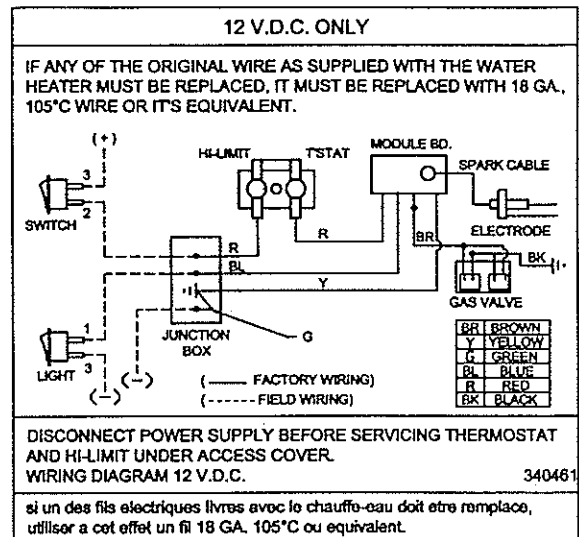

Wiring Diagram 12 V.D.C.

Figure 6

### ELECTRICAL CONNECTION (RE-IGNITOR MODELS)

- A. Applicable to models: SW6 & SW10PR or PER.
- B. Make 12 volt D.C. connections to re-ignitor as illustrated in Figure 7.  
It is recommended to use insulated terminals for all electrical connections.

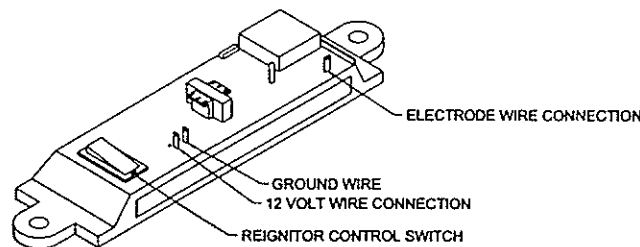

Figure 7

**LIGHTING INSTRUCTIONS FOR PILOT MODELS**  
**OPERATING AND LIGHTING INSTRUCTIONS**  
**APPLICABLE TO MODELS SW3P • SW6P • SW10P • SW3PE • SW6PE • SW10PE**

**WARNING! If you do not follow these instructions exactly, a fire or explosion may result causing property damage, personal injury or loss of life.**

- A. This appliance has a pilot which must be lighted by hand. When lighting the pilot, follow these instructions exactly.
- B. BEFORE LIGHTING smell all around the appliance area for gas. Be sure to smell next to the floor because some gas is heavier than air and will settle on the floor.

**WHAT TO DO IF YOU SMELL GAS**

- Do not try to light any appliance.
  - Do not touch any electric switch.
  - Do not use any phone in your building.
  - Immediately call your gas supplier from a neighbor's phone. Follow the gas supplier's instructions.
  - If you cannot reach your gas supplier, call the fire department.
- C. Use only your hand to push in or turn the gas chock or reset button. Never use tools. If the knob will not push in or turn by hand, do not try to repair it; call a qualified service technician. Force or attempted repair may result in a fire or explosion.
- D. Do not use this appliance if any part has been under water. Immediately call a qualified service technician to inspect the appliance and to replace any part of the control system and any gas control which has been under water.
- E. Before operating heater, check the location of the vent to make sure it will not be blocked by the opening of any door on the trailer. If it can be blocked, do not operate the water heater with the door open.

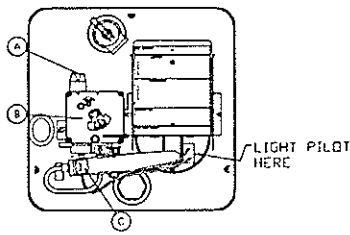

**LIGHTING INSTRUCTIONS**

If the water heater comes equipped with a reignitor control, see "Lighting Instructions for Reignitor Control".

1. **STOP!** Read the safety information provided.
2. Depress and turn knob (A) clockwise → to "OFF" position.
3. Turn off all electric power to the appliance (gas/electric models only).
4. Wait five minutes for gas to clear the area. If you smell gas then STOP! Follow instructions in items B above in the safety information. If you do not smell gas, go to the next step.
5. Depress and turn knob (A) counter clockwise ← to "Pilot" position, press down and light pilot where indicated. (See illustration).

**CAUTION: Do not attempt to light at main burner orifice (C) in illustration.**

6. Hold knob depressed until pilot remains on for 30 seconds. If it does not hold, repeat procedure.
7. Depress and turn knob (A) counter clockwise ← to "ON" position. The control knob has a straight line designation beyond the "ON" position. Turn to this position when moving the valve from the "Pilot" position to the "ON" position.
8. If pilot goes out, repeat steps 2 through 6. On initial start-up, this may take several minutes in order to purge the air from the gas lines and the pilot remain on.
9. Turn on all electrical power to appliance if the combination gas/electric feature is a part of the water heater.
10. Set temperature dial (B) to desired setting.

**CAUTION: Temperature setting on control was factory set at low (120°F/49°C) to reduce risk of scald injury. Setting the temperature dial past the low position will increase the risk of scald injury. Children, disabled, elderly and diabetics are at highest risk of being scalded.**

**TO TURN OFF WATER HEATER**

1. Turn temperature dial (B) clockwise → to the lowest setting.
2. Turn off electrical power to the appliance.
3. Depress and turn knob (A) clockwise → to the "OFF" position.
4. If vehicle is to be stored or heater is going to be turned off while subject to freezing temperature, drain water heater. (See "Draining and Storage Instruction" on page 16.)

**LIGHTING INSTRUCTIONS FOR REIGNITOR MODELS**  
**OPERATING AND LIGHTING INSTRUCTIONS**  
**APPLICABLE TO MODELS SW6PR • SW10PR • SW6PER • SW10PER**

1. **STOP!** Read the safety information provided. (Refer to page 11)
2. Place reignitor control in the "OFF" position.
3. Depress and turn knob (A) clockwise → to "OFF" position.
4. Turn off all electrical power to the appliance. (Gas/Electric models only.)
5. Wait five (5) minutes for gas to clear the area. If you smell gas then, **STOP!** Follow instructions in Item "B" of the safety Information. If you don't smell gas, go to next step.
6. Turn gas supply on.
7. Turn on electrical power to the appliance.
8. Depress and turn knob (A) counter clockwise ← to "Pilot" position, press down and switch the electric reignitor module to "ON" position. Spark will start between electrode tip and pilot hood.
9. When pilot lights, the spark will stop. Continue depressing knob (A) for approximately one minute or until pilot light remains lit. On the initial start-up, it may take several minutes in order to purge the air from the gas lines and the pilot remain on.
10. Depress and turn knob (A) counter clockwise ← to "ON" position. The control knob has a straight line designation beyond the "ON" position. Turn to this position when moving the valve from the "Pilot" position to the "ON" position.
11. Set temperature dial (B) to desired setting.

**CAUTION: Temperature setting on control was factory set at low (120°F/49°C) to reduce risk of scald injury. Setting the temperature dial past the low position will increase the risk of scald injury. Children, disabled, elderly and diabetics are at highest risk of being scalded.**

NOTE: When the reignitor switch is in the "ON" position, the reignitor will operate automatically when the pilot flame is extinguished.

NOTE: When the vehicle is to be stored or the LP gas supply is to be turned off, be sure to turn the reignitor control switch to the "OFF" position. This will prevent the battery from being discharged (the reignitor will continue sparking).

NOTE: The reignitor has an alarm which will sound when the pilot is extinguished or if the LP supply is turned off. The alarm will serve as a reminder to turn off the reignitor.

**TO TURN OFF WATER HEATER**

1. Turn temperature dial (B) clockwise → to lowest setting.
2. Turn off the reignitor.
3. Turn off electrical power to the appliance.
4. Depress and turn knob (A) clockwise → to the "OFF" position.
5. If vehicle is to be stored or heater is going to be turned off while subject to freezing temperatures, drain water heater (See "Draining and Storage Instructions").

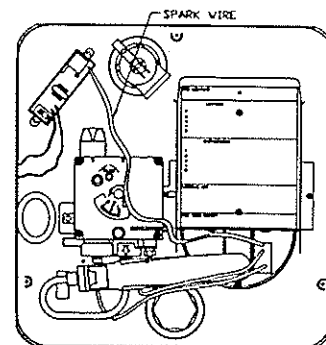
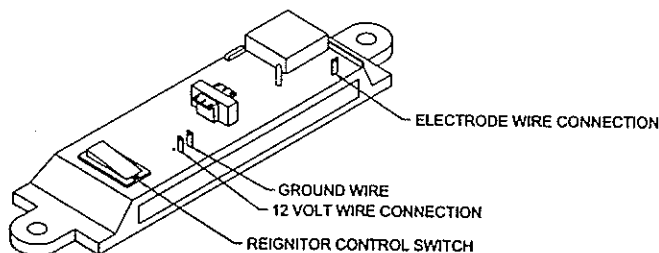

## LIGHTING INSTRUCTIONS FOR DSI MODELS

**WARNING! If you do not follow these instructions exactly, a fire or explosion may result causing property damage, personal injury or loss of life.**

**A.** This appliance does not have a pilot. It is equipped with an ignition device which automatically lights the burner. Do not try to light the burner by hand.

**B.** BEFORE LIGHTING smell all around the appliance area for gas. Be sure to smell next to the floor because some gas is heavier than air and will settle on the floor.

### WHAT TO DO IF YOU SMELL GAS

- Do not try to light any appliance.
- Do not touch any electric switch.
- Do not use any phone in your building.
- Immediately call your gas supplier from a neighbor's phone. Follow the gas supplier's instructions.
- If you cannot reach your gas supplier, call the fire department.

### OPERATING INSTRUCTIONS

1. **STOP!** Read the safety information provided.
2. Turn off all electric power to the appliance.
3. Turn "OFF" gas supply.
4. Wait five minutes for gas to clear the area. If you smell gas then **STOP!** Follow instructions in item B of the safety information. If you don't smell gas, go to next step.
5. Turn "ON" gas supply.
6. Turn on electrical power to the appliance.
7. Turn switch to "ON" position. If the burner does not light, the system will automatically attempt two more tries for ignition before lock-out. NOTE: Each ignition cycle will have a 15 second purge before spark cycle if system is a three try system.
8. If lockout occurs before main burner lights, turn switch to "OFF", wait five seconds and turn switch to "ON" position. This will restart the ignition cycle. The first start-up of the heater may require several ignition cycles before all air is purged from the gas lines.

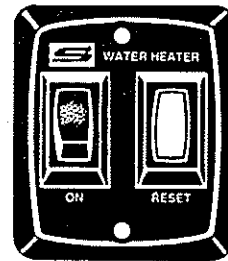

If the burner will not come on, the following items should be checked.

1. Switch turned off.
2. Gas supply to heater is empty or turned off.
3. Reset button on ECO is tripped.

## SEQUENCE OF OPERATION FOR DIRECT SPARK IGNITION

The on/off switch controls the operating circuit to the water heater. If the heater fails to ignite or is in the lockout mode, the light will appear. Also, on startup and during purge cycle, the light can appear for approximately 15-18 seconds.

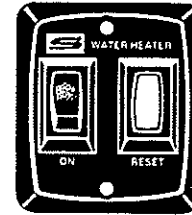

The thermostat-limit controls the power to the module board. At a preset temperature the thermostat will open shutting off the burner. If the thermostat fails, the limit or ECO switch will open and must be manually reset.

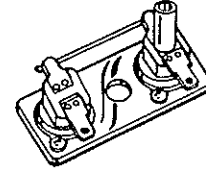

The ignition of the burner is controlled by the direct spark ignition. As module board power is applied to the DSI board, the system will do the following.

1. The DSI board will delay for 5-7 seconds before ignition occurs. The board will then apply current to the gas valve and at the same time also create a high voltage current to the electrode, creating a spark for ignition.

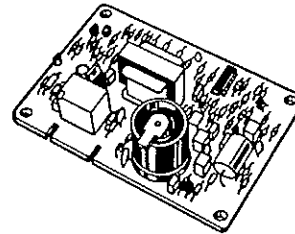

2. The module will then confirm the presence of a flame. If the flame is not detected within 6 seconds the module will stop the firing sequence. The DSI board will try for ignition two times, and will then go into the lockout mode.

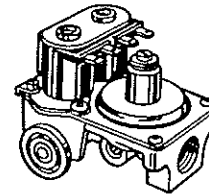

3. To reset the water heater turn the on/off switch to the off position for about 10 seconds and then turn back to the on position.

NOTE: Some DSI module boards will be single try.

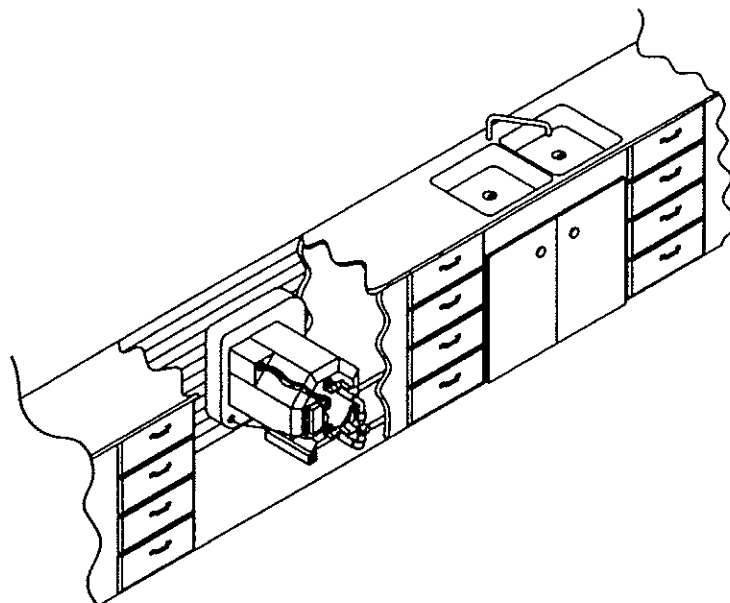
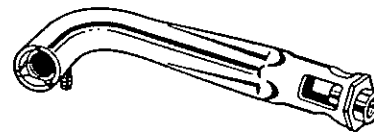
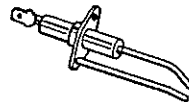

## ELECTRIC ELEMENT

1. An AC electrical heating coil that is immersed in water.

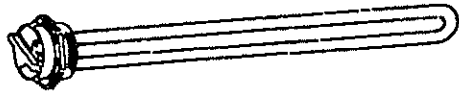

120 VAC  
1440 WATTS  
12 AMPS  
OHM VALUE: 10  
SCREW-IN ELEMENT

### OPERATING INSTRUCTIONS FOR UNITS WITH ELECTRIC ELEMENT

Electric water heaters are designed to operate with a minimum amount of service problems; however, proper operation and care is essential.

By far, the most common trouble with electric water heaters results from energizing the water heater before it is filled with water. Even brief operation of the electric element without water in the tank will burn-out the electric heating element.

To energize the electric heating element, turn the switch to "on". The switch is located behind the water heater door in the lower left corner of the control housing. The water temperature will be regulated by the thermostat.

### TO TURN OFF WATER HEATER

1. Turn switch to "OFF" position.
2. Turn off electrical power to the appliance.
3. Turn off gas supply.
4. If vehicle is to be stored or heater is going to be turned off while subject to freezing temperature, drain water heater. (See "Winterizing Instructions.")

### DRAINING AND STORAGE INSTRUCTIONS

If RV is to be stored during winter months, the water heater must be drained to prevent damage from freezing.

1. Turn off electrical power to water heater either at the switch from the electrical element or a breaker.
2. Shut off gas supply to water heater.
3. Turn off pressure pump on water system.
4. Open both hot and cold water faucets.
5. Remove anode rod from tank.
6. Follow RV manufacturer's instructions for draining entire water system.

NOTE: Be certain to refill water heater with water and remove all air from tank and lines before re-lighting or before turning on electrical power.

### WINTERIZING

If your water heater plumbing system is equipped with a bypass kit, use it to close off the water heater, drain the water heater completely and leave the water heater closed off (out of the system) in the bypass position *particularly* if you are introducing antifreeze into the plumbing system. Antifreeze can be very corrosive to the anode rod creating premature failure and heavy sediment in the tank. If the plumbing system is not equipped with a bypass kit, and you intend to winterize by adding antifreeze to the system, remove the anode rod (storing it for the winter) and replace it with a 3/4" drain plug.

### ODOR FROM HOT WATER SYSTEM

Odor from the hot water system is not a service problem and many water supplies contain sufficient amounts of sulphur to produce an odor. The odor is similar to rotten eggs and is often referred to as "sulphur water". It is not harmful - only unpleasant to smell. Sulphur water can be caused by a chemical action or by bacteria. The solution to eliminate is chlorination of the water system. Add about six (6) ounces of chlorinated common household liquid bleach to each 10 gallons in the water tank. Then run the chlorinated water throughout the system, opening each faucet one at a time until you smell the chlorine. Let the RV sit for a few days and the chlorine should take care of the problem. Then, you will need to take care of the chlorine. Remove the chlorine by flushing the system with fresh water - this may take several attempts. You may consider adding a filtering system that removes chlorine and prevents sulphur water. If the sulphur or rotten egg smell continues, flush the system once again as described above and replace anode rod as necessary.

## ANODE PROTECTION - WATER HEATER

Each Suburban water heater is equipped with a replaceable anode rod. The sacrificial anode equalizes aggressive water action providing cathodic protection for the tank. The anode rod is a very important factor in tank life and should only be removed for inspection or draining. Replacement of the anode rod is recommended when consumption or weight loss is greater than 75%. With regular inspection and replacement of the anode, tank life can be greatly extended. Frequency of anode replacement will vary depending on the water conditions and usage. Sediment on the bottom of the tank forms a layer of insulation between the gas burner and the water. The sediment slows heat transfer and overheats the tank bottom. Overheating weakens the steel and damages the glass lining, shortening the tank life. In addition, it lowers the energy efficiency of the tank.

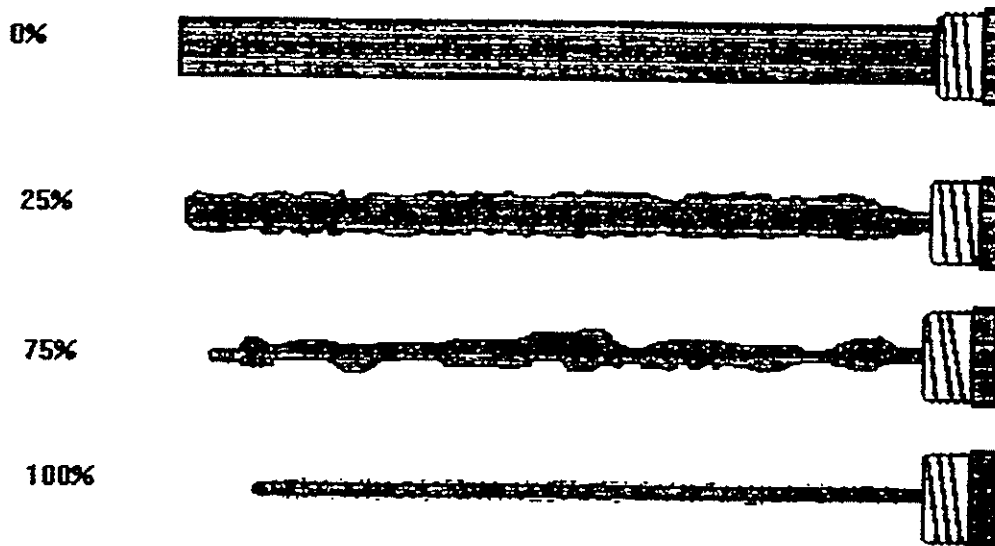

Replacement of the anode rod is recommended when consumption or weight loss is greater than 75%. The sacrificial anode equalizes aggressive water action providing cathodic protection for the tank. The anode is a very important factor in tank life and should only be removed for inspection or draining.

### OPERATING THE WATER HEATER WITHOUT THE ANODE, VOIDS SUBURBAN'S LIMITED WARRANTY.

**WARNING! Do not replace the anode rod with any non-Suburban accessory part, such as an "add-on" electric heating element. Items such as these are not approved to be installed in Suburban products. They could create an unsafe condition and will also void all warranties.**



## PRESSURE RELIEF VALVE

The temperature and pressure relief valve is designed to open if the temperature of the water within the heater reaches 210°F, or if the water pressure in the heater reaches 150 pounds. Recreational vehicle water systems are closed systems and during the water heating cycle the pressure build-up in the water system will reach 150 pounds. When this pressure is reached, the pressure relief valve will open and water will drip from the valve. This dripping will continue until the pressure is reduced to below 150 pounds, and the valve closes. This condition is normal and does not indicate a defective relief valve.

**WARNING! Do not place a valve between the relief valve and the tank. Do not plug the relief valve under any circumstances.**

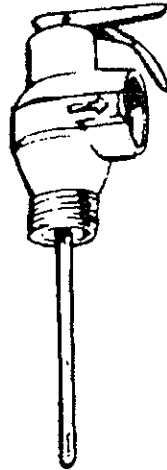

## WATER WEEPING OR DRIPPING FROM PRESSURE RELIEF VALVE

You may experience water weeping or dripping from your water heater's Pressure and Temperature (P & T) Relief Valve when your water heater is operating. Water weeping or dripping from the P & T Valve does not always mean the P & T Valve is defective. As water is heated, it expands. The water system in a recreational vehicle is a closed system and does not allow for the expansion of heated water. When the pressure of the water system exceeds the relieving point of the P & T Valve, the valve will relieve the excess pressure.

Suburban recommends that a check valve not be installed directly at the inlet to the water heater tank. This will increase weeping of the pressure relief valve.

**WARNING! Do not remove or plug the relief valve.**

One way to reduce the frequency of this occurrence is to maintain an air pocket at the top of the water heater tank. This air pocket will form in the tank by design. However, it will be reduced over time by the everyday use of your water heater.

To replenish this air pocket:

1. Turn off water heater.
2. Turn off cold water supply line.
3. Open a faucet in the RV.
4. Pull out on the handle of the Pressure Relief (P & T) Valve and allow water to flow from the valve until it stops.
5. Release handle on P & T Valve - it should snap closed.
6. Close faucet and turn on cold water supply; as the tank fills, the air pocket will develop.

Repeat this procedure as often as needed to reduce the frequency of the weeping of the P & T Valve. If the weeping persists after following this procedure, you may elect to install an expansion or accumulator tank in the cold water line between the tank and check valve to relieve the pressure caused by thermal expansion. Contact your local dealer for assistance.

## ON/OFF SWITCH ASSEMBLY

1. Switch that supplies 12 VDC to water heater.
2. Illuminating light to show no ignition.

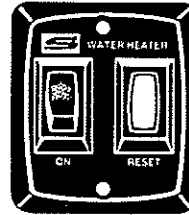

### THERMOSTAT AND LIMIT SWITCH

Models: SW6PE, SW6PER, SW6DE  
SW10PE, SW10PER, SW10DE

### THERMOSTAT AND LIMIT SWITCH

Models: SW6D, SW6DE, SW6DEM  
SW10D, SW10DE, SW10DEM

## THERMOSTAT AND ECO SWITCH

1. A surface mount device that regulates water temperature at a preset temperature.
2. High temperature limit (E.C.O.) used as a resettable cut-off device.
3. Controls voltage to module board

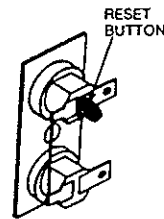

120 VAC T-STAT  
HI-LIMIT

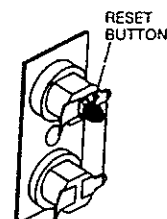

12 VDC T-STAT  
HI-LIMIT

120 Degree (ID# 3212) Not Available  
130 Degree (ID# 2306) Standard  
140 Degree (ID# 2475) Optional

120 Degree (ID# 3213) Not Available  
130 Degree (ID# 2116) Standard  
140 Degree (ID# 2476) Optional

## DIRECT SPARK IGNITION MODULE BOARD

1. An electronic panel that produces high voltage spark ignition source.
2. Produces current to open gas valve coils.
3. Recognizes flame sense current.
4. Three trials for ignition.

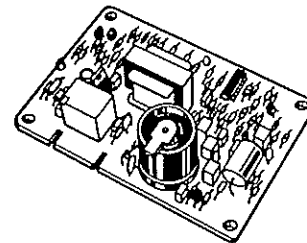

12 VDC  
1.0 AMP DRAW

## ELECTRODE ASSEMBLY

1. A device that conducts high voltage to produce spark.
2. Achieves micro amp signal to create flame sense current.

Micro Amp Value: 3.0 or higher

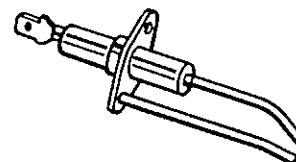

## DIRECT SPARK MODEL

### GAS SOLENOID VALVE

1. A 12 VDC device that regulates flow of gas.
2. Redundant valve.  
OHMS Value: 40 ± 4

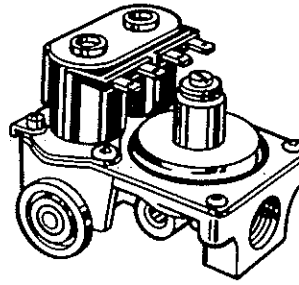

---

## BURNER

1. A gas and air mixing tube that regulates flow of gas from gas valve through orifice to produce flame.
2. Orifice incorporated into burner to regulate the BTU's of combustion.



#61 ORIFICE

---

## THERMOSTAT GAS CONTROL

1. A device used to control temperature and gas flow to main burner and pilot assembly.

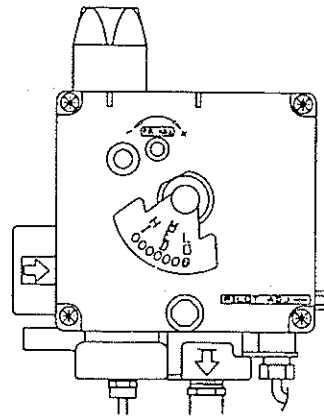

3/8" NPT INLET  
1/4" LOXIT OUTLET

---

## PILOT BURNER ASSEMBLY

1. Pilot line and orifice meters gas through to pilot.
2. Thermocouple is a device that when heated will generate millivolts of electricity to hold magnet open in valve.

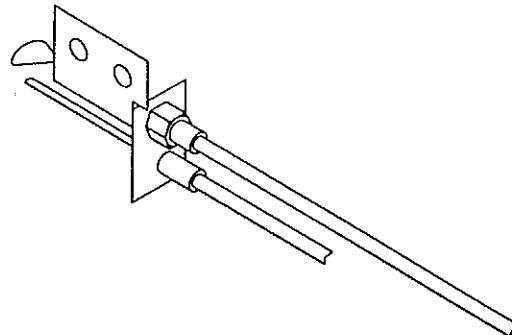

## APPLICATION NOTE FLAME CURRENT MEASUREMENT

### Local Flame Sensing (Single Spark and Sense)

With power off, connect a DC micro ammeter (D'Arsonval movement type) as shown in the diagram below. (The meter should be protected from high voltage surges which could damage the meter movement. A  $1.5\mu\text{F}$  200 volt film capacitor across the meter terminals or lead wires will provide adequate protection.) The lead wires and terminals must be isolated from other surfaces to prevent the H.V. signal from arcing to ground during the trial-for-ignition period.

Apply power. Once the flame is established and the sparks shut off, a flame sense current of  $1.5\mu\text{A}$  DC minimum is required for proper operation.

**CAUTION:** Due to possible conditions, do not touch the micro ammeter or lead wires during the flame sense test. Always remove power before any adjustments.

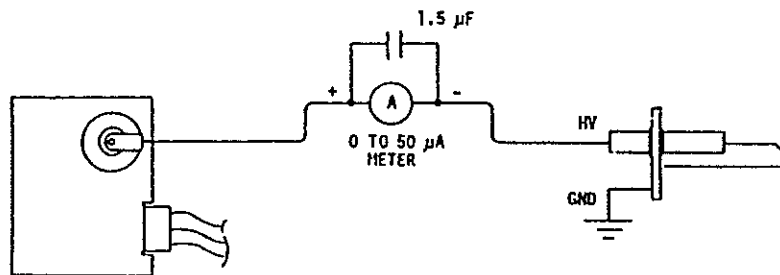

### Local Flame Sensing (Single Spark and Sense)

### Remote Flame Sensing

With power off, remove the sense wire from the electrode terminal and install a DC micro ammeter in series with the electrode terminal and sense wire, as shown in the diagram below.

Apply power. Once flame is established, a flame sense current of  $1.5\mu\text{A}$  DC minimum is required for proper operation.

When Remote Flame Sensing is used, it is not necessary to employ the  $1.5\mu\text{F}$  protection capacitor across the meter. However, since it does not affect the performance of the micro ammeter, it may remain in place at all times.

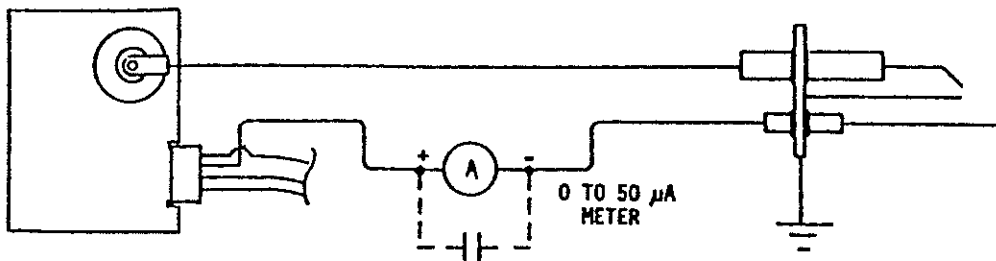

### Remote Flame Sensing

# TROUBLE SHOOTING GUIDE

## SUBURBAN MODELS WATER HEATER

### PILOT IGNITION SECTION

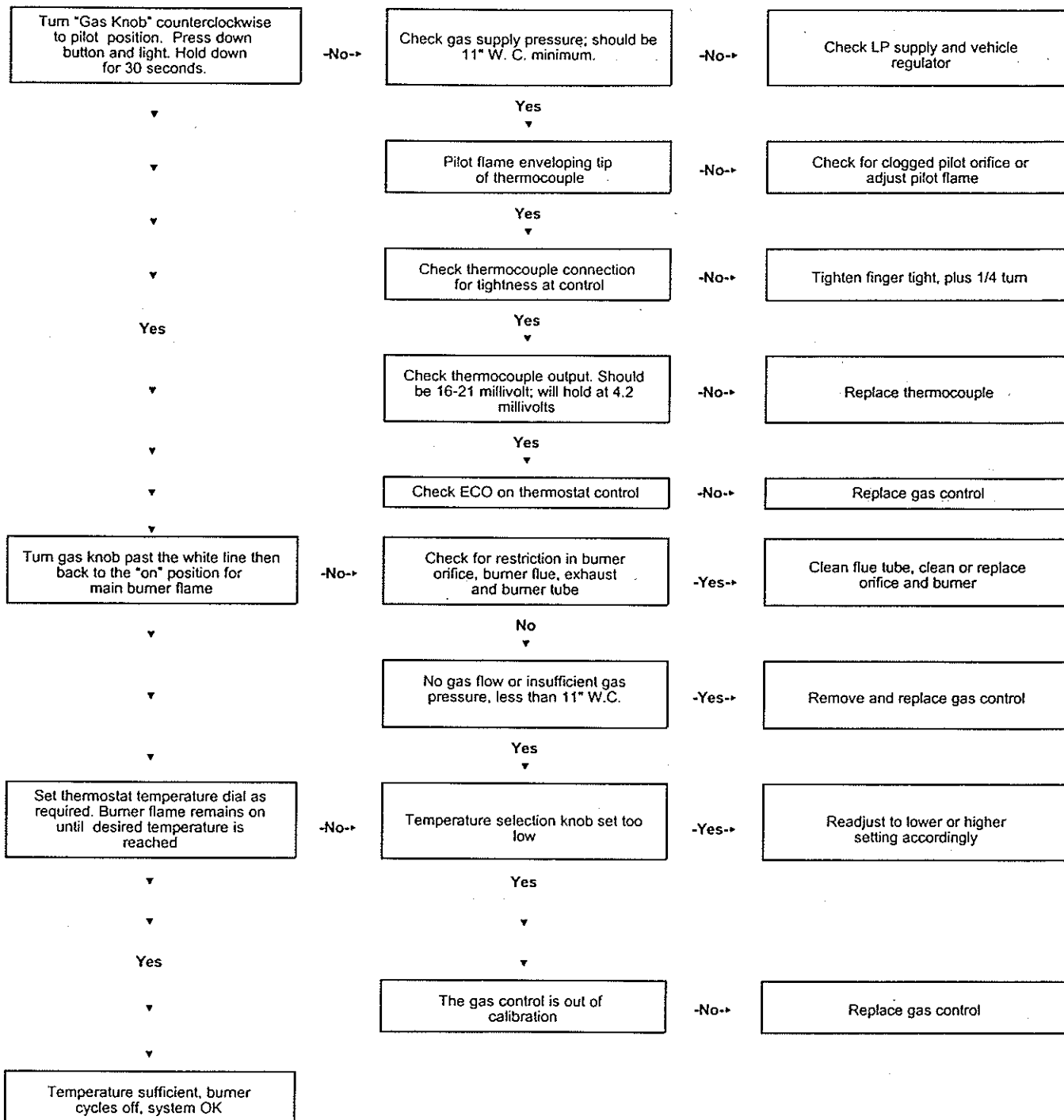

**Note:** Some external weeping of pop-off valve is normal to allow for expansion of the water.

**Note:** You should check or replace the Anode Rod annually.

**Note:** Odor from the water system can be caused by not servicing your Anode, or sulphur water can be caused by a chemical action or by Bacteria so you may flush your tank with a mixture to rid smells. Please see your Owners Manual.

# TROUBLE SHOOTING GUIDE

## SUBURBAN MODEL WATER HEATER

### DIRECT SPARK IGNITION SECTION

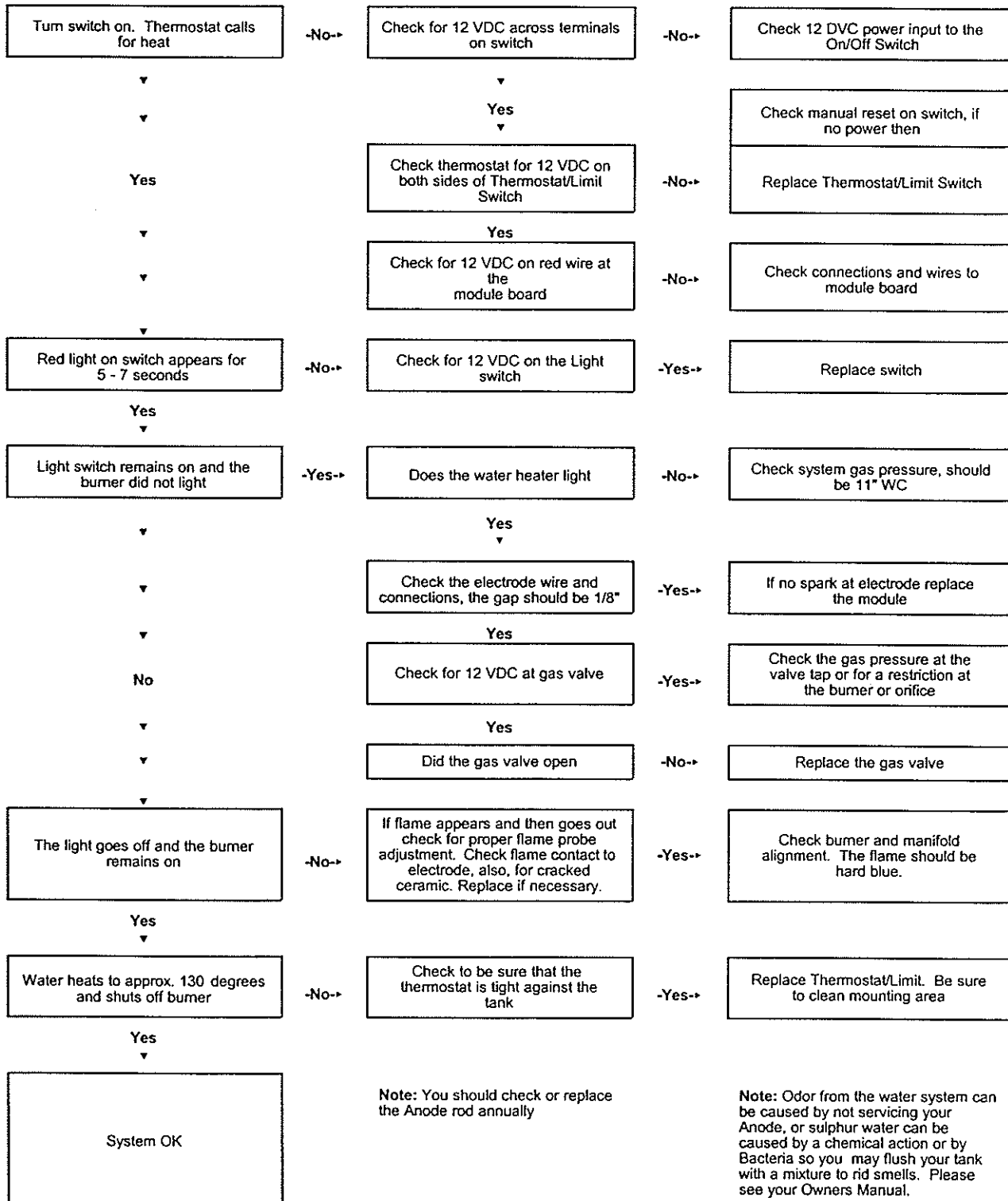

**Note:** Some external weeping may occur at the T&P (Temperature Pressure Relief) to allow for water expansion when heated

**Note:** You should check or replace the Anode rod annually

**Note:** Odor from the water system can be caused by not servicing your Anode, or sulphur water can be caused by a chemical action or by Bacteria so you may flush your tank with a mixture to rid smells. Please see your Owners Manual.

# TROUBLE SHOOTING GUIDE

## SUBURBAN MODEL WATER HEATER

### ELECTRIC ELEMENT SECTION

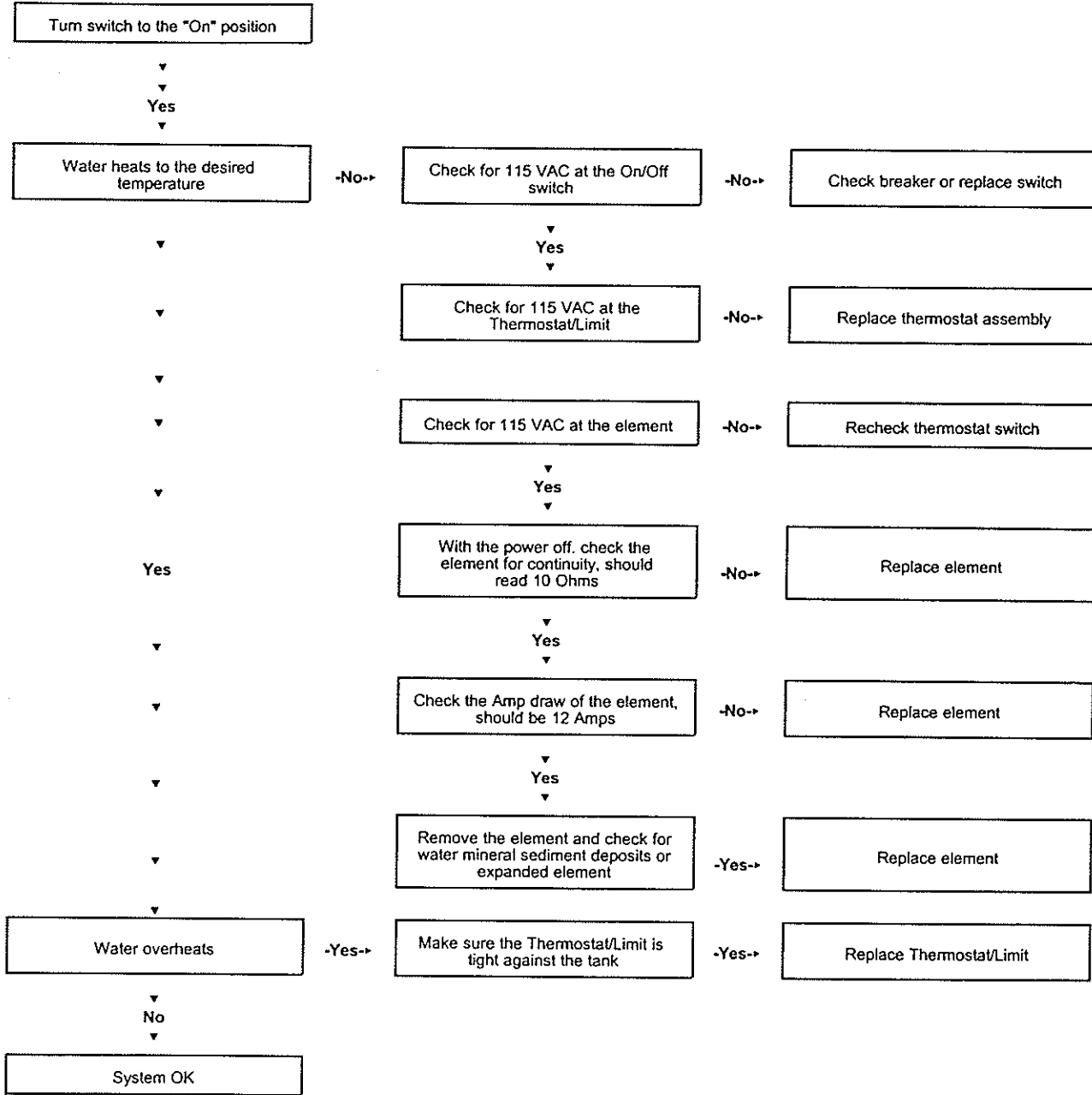

**Note:** Some external weeping may occur at the T&P (Temperature Pressure Relief) to allow for water expansion when heated

**Note:** You should check or replace the Anode rod annually

**Note:** Odor from the water system can be caused by not servicing your Anode, or sulphur water can be caused by a chemical action or by Bacteria so you may flush your tank with a mixture to rid smells. Please see your Owners Manual.